

®

Excellock

www.excelhydro.com



Excellock®

INSTRUMENT VALVES
AND
ACCESSORIES



The proven leader in fluid control technology



Excel Hydro-Pneumatics and Hydro-Pneumatic Accessories manufacture high technology products for petroleum and process industries applications. The company aims to be a leading partner to system builders and user of high pressure fittings, valves and components. The product range includes standardized high pressure ratings up to 30000 PSI, made of stainless steel AISI 316 or high graded alloys and special materials.



' National Award for Excellence 1995 '
At the hands of Shri S. Krishnakumar,
Minister for Non-conventional Energy sources
at New Delhi



'National Award for Export Excellence 1995'
At the hands of Shri Rajiv Pratap Rudy,
Minister of State for Commerce and Industry



Our Beginning

Excel - Hydro was established in 1986 in Mumbai , India and started with manufacturing of tube / pipe fittings and isolation valves. The experience gained in the metal processing sector proved an excellent basis for diversification into various high technology areas and led to the subsequent manufacturing of high quality manifold valves, multi port gauge valves, check valves, ball valves, precision double compression ferrule fittings, distribution manifolds, condensate pots, quick couplers, pipe clamps and instrument enclosures, canopy, etc.

Quality Standards



High quality and safety standards are maintained through a Total Quality Management System. **We are Accredited for ISO 9001-2000 by TUV NORD, GERMANY as the " Design, Manufacture and Supply of Instrumentation Valves and Fittings"** Organization. Our effectively implemented control systems all through the organization ensures, that only the Quality products are delivered to all our customers.

The products are type tested for Helium leak test, Seismic test by ECIL (NPCL- DAE) and C_v test by Indian Institute of Technology, Powai, Mumbai . We have full fledged required in-house testing facilities.



Excelock

CONTENTS

Introduction

Page 01-03

Needle Valves

Page 04 - 10

E 101 NV & E 102 NV

E 103 NV & E 104 NV

E 105 NV & E 106 NV

E 107 NV & E 108 NV

E 109 NV

E 3WNV

Ball Valves

Page 11 - 19

E 210 - BV

E 220S - BV

E 230B - BV

E 240A - BV

E 220T - BV

E 250W3 - BV

E 250W3T - BV

E 250W4 - BV

E 250W5 -BV

Gate / Globe / Check Valves

Page 20 - 25

E 210 GV

E 210SR - GV

E 210FF - GV

E 210 - CKV

E 210SW - GB

E 220SW - GB

Accessories

Page 26 -32

Sample Cylinder

Condensate & Seal Pot

Instrument Enclosures

Air Distribution Manifold & Other Accessories

General Features

Excellock Barstock Needle Valves are specially designed Needle Valves for operation with most of the Fluids up to 6000 psig (414 barg) and on special request up to 30,000psig (2068 barg) ratings. These valves are complete with PTFE gland packing or with Graphoil gland packing (For high temperature applications). Placing the gland packing below the stem thread ensures that the process does not get in contact with the Stem threads. Tightening of the upper gland body ensures perfect sealing of the gland packing and arrests leakage.

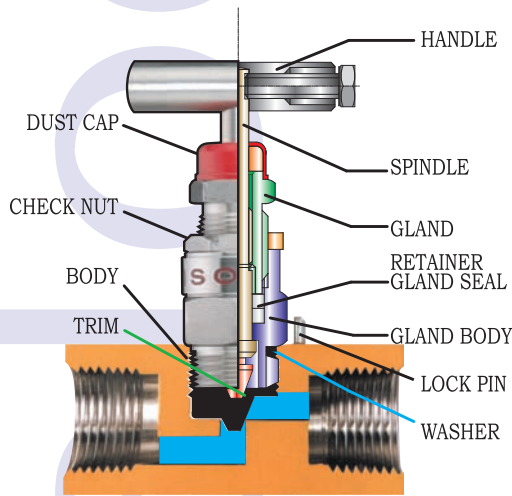

The lock nut ensures that the upper gland body is locked to a particular setting. The lower gland body is directly screwed onto the main body and fixed with a pin to prevent accidental loosening of the gland body while in operation. For special applications soft seating is also available. A wide variety of end connections can be offered based on customer requirements. NACE Compliance and Oxygen(O₂) clean service valves are also available with wide varieties of materials of construction

Specifications

- Standard seat diameter 5 mm
- CV: 0.4 Standard
- Maximum standard pressure up to 6,000 psig (414 barg)
- Optional Maximum pressures up to 30,000 psig (2068 barg)
- Temperature Rating - 54°C to + 640°C (-65°F To +1200°F)
- For Valve sizes and combinations, refer to following pages
- Panel mount option on specific request

Features

- Stellite trim and seat can be provided as optional feature for high pressure and high temperature applications
- Soft seated seats, both renewable and non-renewable types can be supplied based on customer requirements. Renewable types provides straight through flow path with high flow capacity bi-directional flow, and rodding capabilities.
- All Valves are 100% factory tested.
- NACE certified wetted parts are available
- Bonnet locking pin is fitted as standard Valves are suitable for Gaseous and Aggressive fluid services
- Low Torque operating T bar Handle
- Valves can be supplied with variety of MOC for Body, Stem, Trim, Glands etc
- Externally adjustable gland

- Angled version available
- Fire safe option available to API607, BS 6755 Part 2 (on specific request)

- Stem** : Rolled and burnished stems at the packing area
- Trim** : Non-rotating trim enabling self centering of the spindle with the orifice providing bubble tight shut off
- Packing** : PTFE packing standard, optional Graphoil for high temperature applications.
- Spindle** : Backseat stop spindle for blowout prevention
- Dust Cap** : Protective dust caps provided in general to prevent ingress of contaminants.



Materials Standards

The Valve Body can be supplied in different materials as outlined below. The Code No customer has to specify is given in the ordering sheet.

Material	Bar Stock	Forging	UNS
316 St Steel	ASTM A-276 ASTM A-479	ASTM A-182 F-316	S31600
316L St Steel	ASTM A-276 ASTM A-479	ASTM A-182 F-316L	S31603
Carbon Steel	ASTM A-108	ASTM A-105	-
Alloy-20	ASTM B-473	ASTM B-462	No8020
Titanium	ASTM B-348	ASTM B-381	R50400
Hastelloy	ASTM B-574	ASTM B-564	N10276
Brass	ASTM B-16 IS-319	ASTM B-283	
Alloy-400	ASTM B-164	ASTM B-564	N04400
Alloy- 600	ASTM B-166	ASTM B-564	N06600
Duplex St Steel			S31803

Material of Construction - Valves Components

Valve Body	Stem / Trim Gland & Gland Washer	Retainer	Handle
316 St Steel	316 St Steel	304 St Steel	304 St Steel
316L St Steel	316L St Steel	304 St Steel	304 St Steel
Titanium	Titanium	304 St Steel	304 St Steel
Alloy - 400 / 600	Alloy - 400 / 600	304 St Steel	304 St Steel
Hastelloy C 276	Hastelloy C 276	304 St Steel	304 St Steel
Duplex St Steel	Duplex St Steel	304 St Steel	304 St Steel
Brass	316 St. Steel Brass Copper	Brass	CS
CS	316 St. Steel CS Copper	CS	CS

Note : All CS components are Zinc plated .

Any other combination - optional on request

Valves for Cryogenic Applications

Excellock offers valves for Cryogenic applications also. The material standard for all valves are 316L Stainless Steel as standard

Gland Packing Materials

PTFE (Poly Tetra Fluro Ethylene): is standard for all valves up to an operating temperature of 240°C Max. PTFE is in the form of Rings.

Graphoil is recommend for operating temperature above 240°C. Graphoil packing contains no resin binders, it is self lubricating at all temperatures.

Soft Seat Material

PTFE	:	69 barg	up to	60°C
		14 barg	up to	250°C
DELFIN	:	414 barg	up to	90°C
PEEK	:	414 barg	up to	90°C
		138 barg	up to	200°C

Cleaning

Excellock valves are thoroughly cleaned, during the assembly stage, component wise and dried. After assembly and testing they are thoroughly cleaned and dried again

Special procedures for cleaning for Oxygen (O₂) service, Chlorine service and as per MSS standard requirements are also carried out on request.

Pressure Vs. Temperature

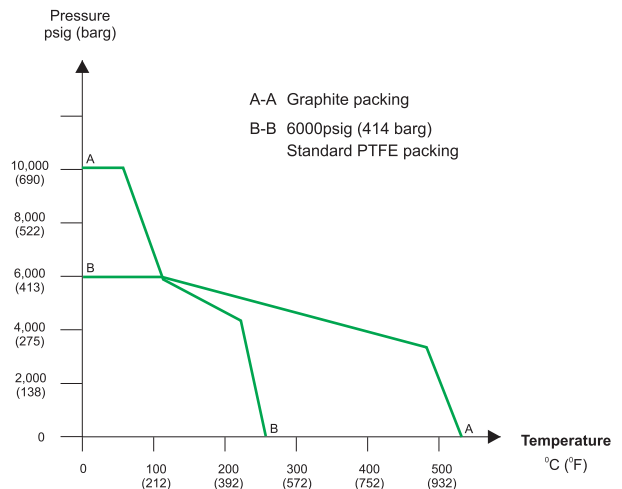



Thread Specifications

Thread Type	Ref.Specifications
NPT	ASME B1.20.1, SAE AS 71051
ISO/BSP(Parallel)	ISO 228 , BS 2779, JIS B 0202
ISO/BSP(Tapered)	ISO 7 , BS 21, JIS B 0203
ISO/BSP(Gauge) Unified(SAE)	ISO 228 , BS 2779 ASME B1.1

A thread sealant or Teflon tape should always be used when assembling tapered threads.

All Excellock Valve components are cleaned to remove machine oil grease, and loose particles.

Recommended operating Pressures

SS-316/316L/CS/: 6,000 Psig (414 barg)
 Monel /Titanium / Optional
 Alloy-20, 400, 600 10,000 Psig (690 barg)
 Hastelloy-C/ Duplex

Ball Valves

Excellock Ball Valves are preferred where operation requires less torque. The quarter turn design facilitate easy operation.

Ball Valves are used where full flow is required. Not recommended for flow throttling purpose.

Our range covers variety of types and end connections :

- 2 way
- 3 way
- 4 way
- 5 way
- Panel mount
- Screwed ends
- Tube ends
- Flanged ends

Test Pressures

Excellock Valves are tested as per the following standards

As per MSS-SP-90

Test pressure at 25°C Room Temperature

Hydrostatic : Body 414 Kg/cm²

Seat 150 Kg/cm²

Pneumatic : Seat 40 Kg/cm²

As per ANSI-B 16.5

Test pressure at 25°C Room Temperature

Hydrostatic : Body 630 Kg/cm²

Pneumatic : Seat 7 Kg/cm²

The above figures are for valves with 6,000 psig working pressure. For valves with 10,000 psig multiply the above figure 1.5 times. However pneumatic seat leakage test pressure is at the same values.



Needle Valve : FNPT X FNPT : E 101 NV

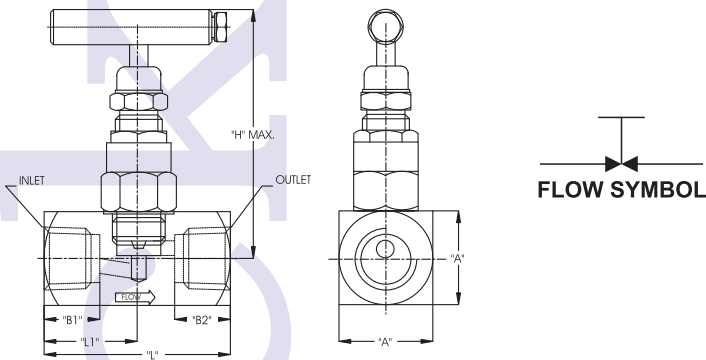

Dimensions (in millimeters)

MODEL NO	INLET	OUTLET	A	B1	B2	L	L1	H
E 101 NV2	1/8"	1/8"	28.00	10.00	10.00	56.00	28.00	87.00
E 101 NV4	1/4"	1/4"	28.00	14.00	14.00	56.00	28.00	87.00
E 101 NV6	3/8"	3/8"	28.00	14.00	14.00	56.00	28.00	87.00
E 101 NV8	1/2"	1/2"	32.00	19.00	19.00	68.00	34.00	89.00
E 101 NV12	3/4"	3/4"	40.00	19.00	19.00	68.00	34.00	93.00
E 101 NV16	1"	1"	45.00	24.00	24.00	80.00	40.00	108.00

* End connections other threads on request.

Needle Valve : MNPT X FNPT : E 102 NV

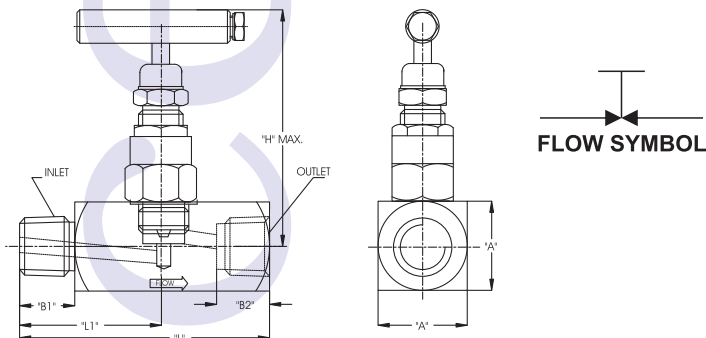

Dimensions (in millimeters)

MODEL NO	INLET	OUTLET	A	B1	B2	L	L1	H
E 102 NV2	1/8"	1/8"	28.00	10.00	10.00	68.00	40.00	87.00
E 102 NV4	1/4"	1/4"	28.00	14.00	14.00	76.00	46.00	87.00
E 102 NV6	3/8"	3/8"	28.00	14.00	14.00	76.00	46.00	87.00
E 102 NV8	1/2"	1/2"	32.00	19.00	19.00	88.00	56.00	89.00
E 102 NV12	3/4"	3/4"	40.00	19.00	19.00	88.00	56.00	93.00
E 102 NV16	1"	1"	45.00	24.00	24.00	104.00	62.00	108.00

* End connections other threads on request.

Note : ALL DIMENSIONS ARE SUBJECT TO CHANGE WITHOUT NOTICE.



Needle Valve : MNPT X MNPT : E 103 NV

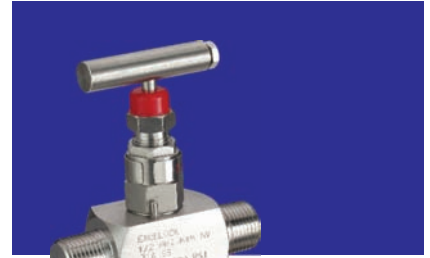
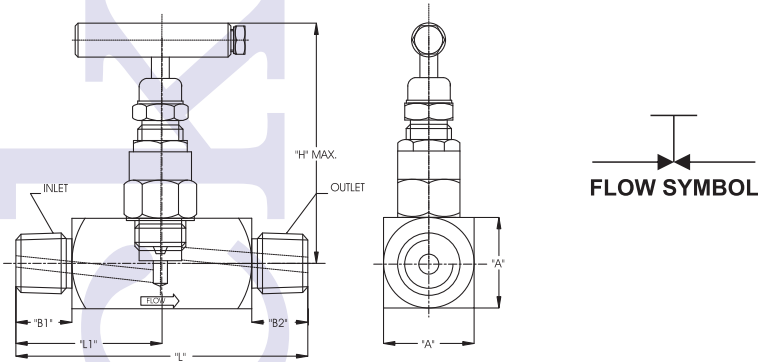

Dimensions (in millimeters)

MODEL NO	INLET	OUTLET	A	B1	B2	L	L1	H
E 103 NV2	1/8"	1/8"	28.00	10.00	10.00	76.00	38.00	87.00
E 103 NV4	1/4"	1/4"	28.00	14.00	14.00	80.00	40.00	87.00
E 103 NV6	3/8"	3/8"	28.00	14.00	14.00	80.00	40.00	87.00
E 103 NV8	1/2"	1/2"	32.00	19.00	19.00	89.00	44.50	89.00
E 103 NV12	3/4"	3/4"	32.00	19.00	19.00	89.00	44.50	89.00
E 103 NV16	1"	1"	45.00	24.00	24.00	105.00	52.50	108.00

* End connections other threads on request.

Needle Valve : FNPT X MNPT : E 104 NV

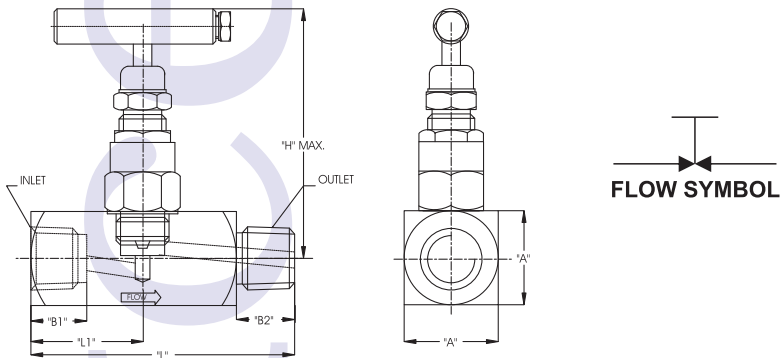

Dimensions (in millimeters)

MODEL NO	INLET	OUTLET	A	B1	B2	L	L1	H
E 104 NV2	1/8"	1/8"	28.00	10.00	10.00	68.00	40.00	87.00
E 104 NV4	1/4"	1/4"	28.00	14.00	14.00	76.00	46.00	87.00
E 104 NV6	3/8"	3/8"	28.00	14.00	14.00	76.00	46.00	87.00
E 104 NV8	1/2"	1/2"	32.00	19.00	19.00	88.00	56.00	89.00
E 104 NV12	3/4"	3/4"	40.00	19.00	19.00	88.00	56.00	93.00
E 104 NV16	1"	1"	45.00	24.00	24.00	104.00	62.00	108.00

* End connections other threads on request.

Note : ALL DIMENSIONS ARE SUBJECT TO CHANGE WITHOUT NOTICE.



Angle Type Needle Valve : FNPT X FNPT : E 105 NV

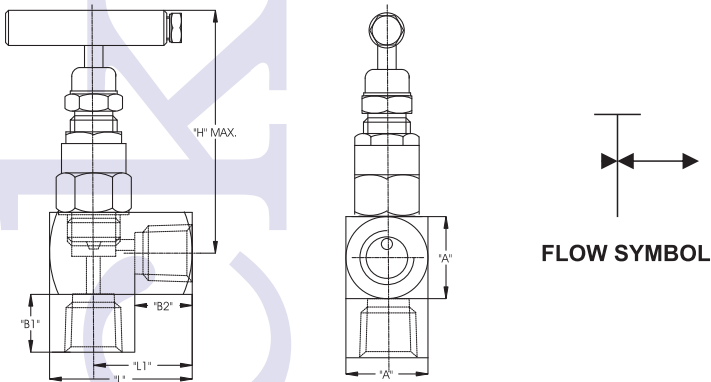

Dimensions (in millimeters)

MODEL NO	INLET	OUTLET	A	B1	B2	L	L1	H
E 105 NV2	1/8"	1/8"	28.00	10.00	10.00	44.00	29.00	87.00
E 105 NV4	1/4"	1/4"	28.00	14.00	14.00	44.00	29.00	87.00
E 105 NV6	3/8"	3/8"	28.00	14.00	14.00	44.00	29.00	87.00
E 105 NV8	1/2"	1/2"	32.00	19.00	19.00	50.00	35.00	89.00
E 105 NV12	3/4"	3/4"	40.00	19.00	19.00	50.00	35.00	93.00
E 105 NV16	1"	1"	45.00	24.00	24.00	72.00	49.50	108.00

* End connections other threads on request.

Angle Type Needle Valve : MNPT X FNPT : E 106 NV

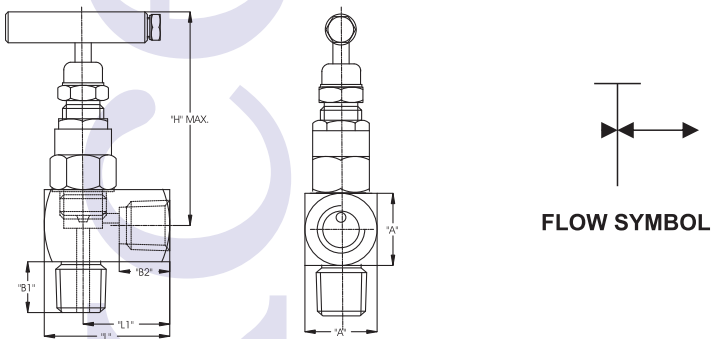

Dimensions (in millimeters)

MODEL NO	INLET	OUTLET	A	B1	B2	L	L1	H
E 106 NV2	1/8"	1/8"	28.00	10.00	10.00	44.00	29.00	87.00
E 106 NV4	1/4"	1/4"	28.00	14.00	14.00	44.00	29.00	87.00
E 106 NV6	3/8"	3/8"	28.00	14.00	14.00	44.00	29.00	87.00
E 106 NV8	1/2"	1/2"	32.00	19.00	19.00	50.00	35.00	89.00
E 106 NV12	3/4"	3/4"	40.00	19.00	19.00	50.00	35.00	93.00
E 106 NV16	1"	1"	45.00	24.00	24.00	72.00	49.50	108.00

* End connections other threads on request.

Note : ALL DIMENSIONS ARE SUBJECT TO CHANGE WITHOUT NOTICE.



Angle Type Needle Valve : MNPT X MNPT : E 107 NV

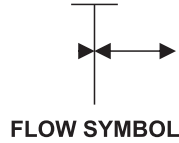
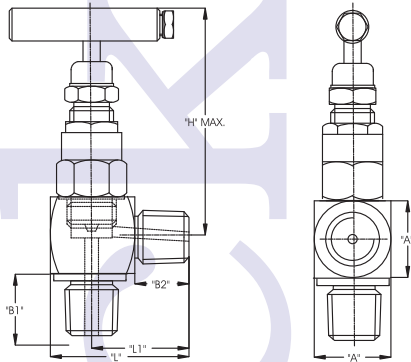

Dimensions (in millimeters)

MODEL NO	INLET	OUTLET	A	B1	B2	L	L1	H
E 107 NV2	1/8"	1/8"	28.00	10.00	10.00	44.00	29.00	87.00
E 107 NV4	1/4"	1/4"	28.00	14.00	14.00	44.00	29.00	87.00
E 107 NV6	3/8"	3/8"	28.00	14.00	14.00	44.00	29.00	87.00
E 107 NV8	1/2"	1/2"	32.00	19.00	19.00	50.00	35.00	89.00
E 107 NV12	3/4"	3/4"	40.00	19.00	19.00	50.00	35.00	89.00
E 107 NV16	1"	1"	45.00	24.00	24.00	72.00	49.50	108.00

* End connections other threads on request.

Angle Type Needle Valve : FNPT X MNPT : E 108 NV

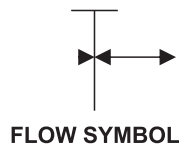
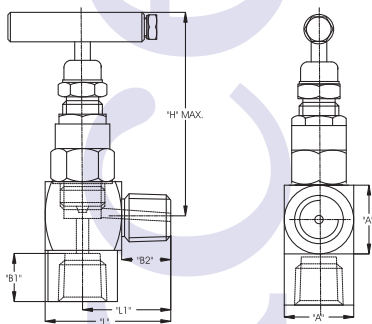

Dimensions (in millimeters)

MODEL NO	INLET	OUTLET	A	B1	B2	L	L1	H
E 108 NV2	1/8"	1/8"	28.00	10.00	10.00	44.00	29.00	87.00
E 108 NV4	1/4"	1/4"	28.00	14.00	14.00	44.00	29.00	87.00
E 108 NV6	3/8"	3/8"	28.00	14.00	14.00	44.00	29.00	87.00
E 108 NV8	1/2"	1/2"	32.00	19.00	19.00	50.00	35.00	89.00
E 108 NV12	3/4"	3/4"	40.00	19.00	19.00	50.00	35.00	89.00
E 108 NV16	1"	1"	45.00	24.00	24.00	72.00	49.50	108.00

* End connections other threads on request.

Note : ALL DIMENSIONS ARE SUBJECT TO CHANGE WITHOUT NOTICE.



Needle Valve : Tube OD X Tube OD : E 109 NV

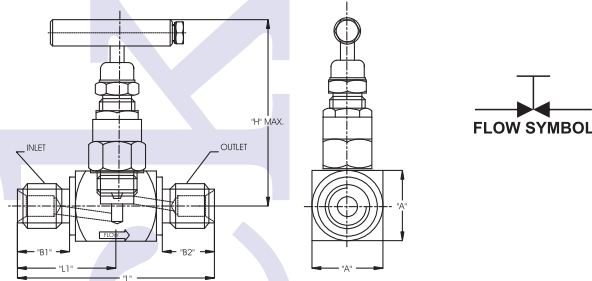

Needle Valve : Panel Mounted Tube OD X Tube OD : Refer ** for Model No.

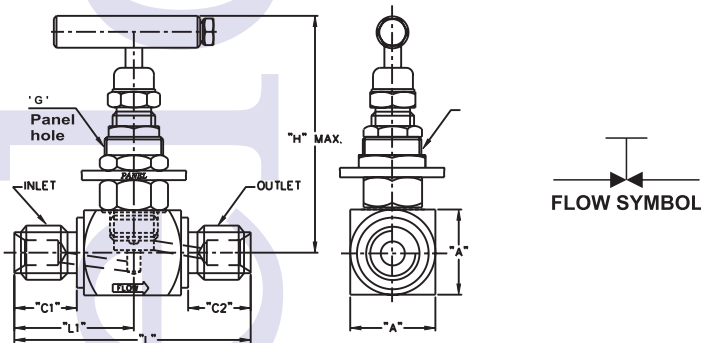

Dimensions (in millimeters)

MODEL NO	INLET (Tube OD)	OUTLET (Tube OD)	A	B1	B2	L	L1	H	G (Panel hole)
E 109 NV2	1/8"	1/8"	28.00	16.00	16.00	60.00	30.00	87.00	19.00
E 109 NV4	1/4"	1/4"	28.00	19.00	19.00	66.00	33.00	87.00	19.00
E 109 NV6	3/8"	3/8"	28.00	21.00	21.00	70.00	35.00	87.00	19.00
E 109 NV8	1/2"	1/2"	32.00	22.00	22.00	88.00	44.00	87.00	28.00
E 109 NV12	3/4"	3/4"	38.00	26.00	26.00	90.00	45.00	100.00	28.00
E 109 NV16	1"	1"	42.00	29.00	29.00	100.00	50.00	110.00	34.00
E 109 NV6mm	6mm	6mm	28.00	19.00	19.00	66.00	33.00	87.00	19.00
E 109 NV10mm	10mm	10mm	28.00	20.00	20.00	68.00	34.00	87.00	19.00
E 109 NV12mm	12mm	12mm	32.00	22.00	22.00	88.00	44.00	87.00	28.00
E 109 NV14mm	14mm	14mm	38.00	24.00	24.00	86.00	43.00	100.00	28.00
E 109 NV16mm	16mm	16mm	38.00	24.00	24.00	86.00	43.00	100.00	28.00
E 109 NV25mm	25mm	25mm	42.00	29.00	29.00	100.00	50.00	110.00	34.00

** For Panel mount suffix part no with A

Note : ALL DIMENSIONS ARE SUBJECT TO CHANGE WITHOUT NOTICE.



**GUAGE VALVE
E 3WNV**

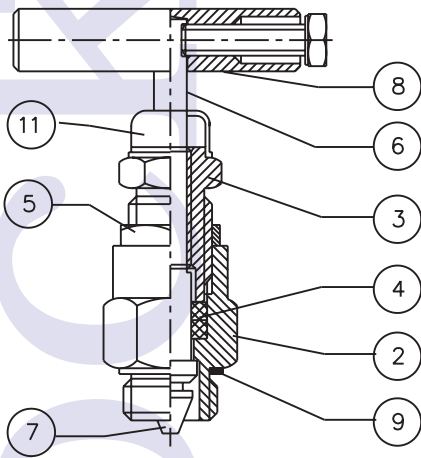

PART No.	PART DESCRIPTION	MATERIAL	QTY
1	BODY	SS 316	1
2	GLAND BODY	SS 316	1
3	GLAND RETAINER	SS 304	1
4	GLAND SEAL	P.T.F.E.	2
5	CHECK NUT	SS 304	1
6	SPINDLE	SS 316	1
7	TRIM	SS 316	1
8	HANDLE	SS 304	1
9	WASHER	S.S.	1
10	LOCK PIN	SS 304	1
11	DUST CAP	P.V.C.	1
12	DRAIN PLUG 1/4"NPT(M)	SS 316	1

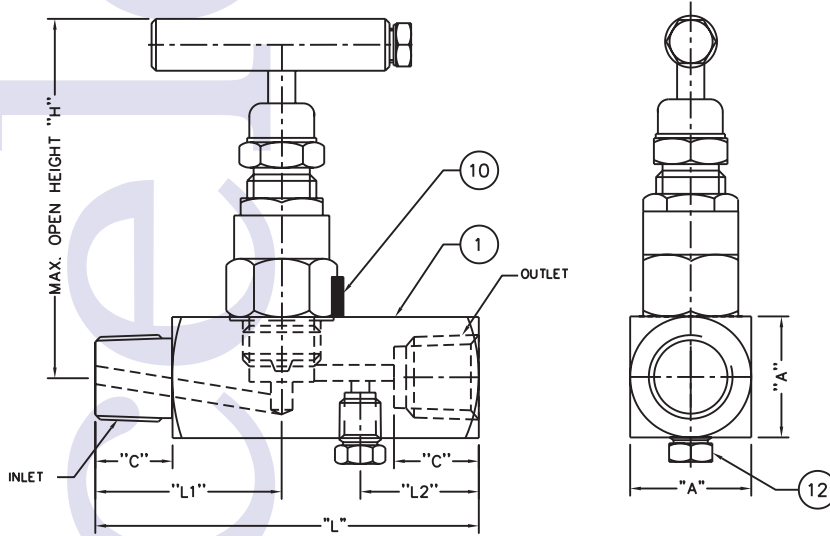

MODEL No.	INLET	OUTLET	"L"	"L1"	"L2"	"A"	"C"	"H"
E 3WNV-4	1/4"NPT(M)	1/4"NPT(F)	78.0	32.0	30.0	28.0	14.0	87.0
E 3WNV-6	3/8"NPT(M)	3/8"NPT(F)	78.0	32.0	30.0	32.0	14.0	87.0
E 3WNV-8	1/2"NPT(M)	1/2"NPT(F)	88.0	44.0	31.0	32.0	19.0	89.0
E 3WNV-12	3/4"NPT(M)	3/4"NPT(F)	88.0	44.0	31.0	40.0	19.0	93.0

Note : END CONNECTIONS AVAILABLE IN VARIOUS COMBINATIONS WITH MALE THREADS, FEMALE THREADS, TUBE END CONNECTIONS.
Option : BLEED VALVE can be provided instead of Drain Plug

Note : ALL DIMENSIONS ARE SUBJECT TO CHANGE WITHOUT NOTICE.



Ordering Information
NEDDLE VALVE

Base Model	Please refer to individual catalog sheet			
	Body Material	1	316 Stainless Steel	
2		316L Stainless Steel		
3		304 Stainless Steel		
4		304L Stainless Steel		
5		Hastelloy C-276		
6		Carbon Steel		
7		Alloy 20		
8		Titanium		
9		Alloy 400		
10		Alloy 600		
11		Duplex Stainless Steel		
Thread Type	N	NPT Threads to ASME B1.20		
	B	BSPP Threads to ISO 228/1		
	BT	BSPT Threads to ISO 7/1		
Gland Packing	S	Standard PTFE		
	G	Graphoil		
	P	Peek		
Seat	I	Integral (Body Material)		
	T	Soft seat-PTFE		
	D	Soft seat-DELRIN		
	P	Soft seat-PEEK		
Options	A	Panel Mount		
	B	Angular Mounting Bracket		
	C	Stellite of Trims		
	D	Cleaned for O ₂ Service		
	E	NACE-MR-01-75		

TYPICAL MODEL NO.: E 101 NV8 - 1 - N - S - I

Safety Notes :

Customer to select suitable type and size of the valves based on their applications.
For Safe, easy installation & maintenance free operation ; Material compatibility, temperature and pressure ratings must be considered during selection of valves.



**BALL VALVE (2 PC DESIGN)
E210 - BV**

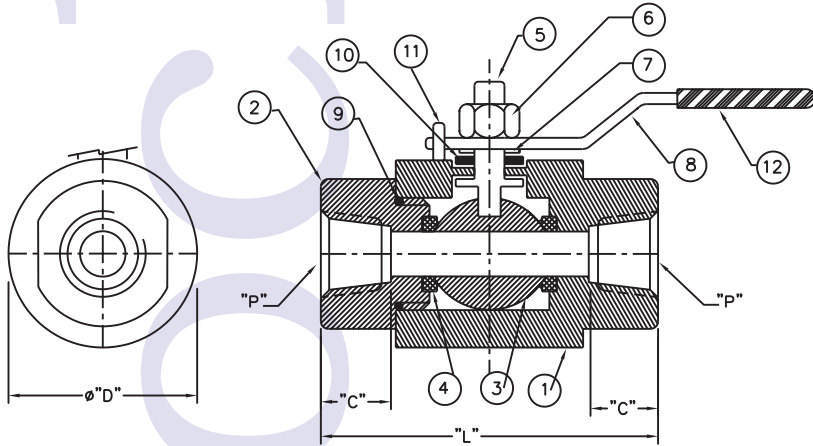

PART No.	DESCRIPTION	MATERIAL	QTY
1	BODY	SS316	1
2	ADAPTOR	SS316	1
3	BALL	SS 316	1
4	SEAT RING	P.T.F.E.	2
5	STEM	SS 316	1
6	NUT	SS 304	1
7	WASHER	SS 316	1
8	HANDLE	SS 304	1
9	'O' RING	BUNA -N	1
10	GLAND SEAL	P.T.F.E.	1
11	STOP PIN	SS304	1
12	HANDLE SLEEVE	P.V.C.	1

MODEL NO.	"P" THREAD	"L" ±2.0	Ø"D" ±2.0	"C" ±1.0	TEST PRESSURE HYDRO	
					BODY	SEAT
E210 -BV4	1/4"NPT(F)	58.0	32.0	14.0	3000 PSI	2000 PSI
E210 -BV6	3/8"NPT(F)	58.0	32.0	14.0	3000 PSI	2000 PSI
E210 -BV8	1/2"NPT(F)	75.0	38.0	19.0	3000 PSI	2000 PSI
E210 -BV12	3/4"NPT(F)	80.0	45.0	19.0	3000 PSI	2000 PSI
E210 -BV16	1.0"NPT(F)	87.0	55.0	22.0	3000 PSI	2000 PSI

Note : ALL DIMENSIONS ARE SUBJECT TO CHANGE WITHOUT NOTICE.



BALL VALVE (3 PC DESIGN) E220S - BV

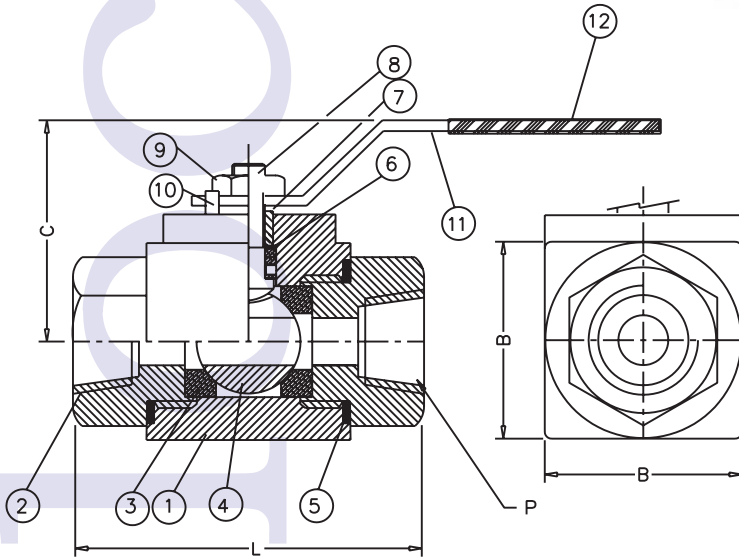

PART No.	PART DESCRIPTION	MATERIAL	QTY
1	BODY	SS316	1
2	ADAPTOR	SS316	2
3	SEAT RING	P.T.F.E.	2
4	BALL	SS316	1
5	GASKET	P.T.F.E.	2
6	GLAND SEAL	P.T.F.E.	2
7	RETAINER NUT	SS316	2
8	STEM	SS316	1
9	LOCK NUT	SS316	1
10	STOPPER PIN	SS316	1
11	HANDLE	SS304	1
12	HANDLE SLEEVE	P.V.C.	1

MODEL NO.	P NPT(F)	B	L	C	TEST PRESSURE HYDRO	
E220S-BV4	1/4"	28.0	62.0	42.0	3000 PSI BODY	2000 PSI SEAT
E220S-BV6	3/8"	28.0	62.0	42.0	3000 PSI BODY	2000 PSI SEAT
E220S-BV8	1/2"	35.0	85.0	60.0	3000 PSI BODY	2000 PSI SEAT
E220S-BV12	3/4"	40.0	100.0	60.0	3000 PSI BODY	2000 PSI SEAT
E220S-BV16	1.0"	50.0	110.0	75.0	3000 PSI BODY	2000 PSI SEAT

Note : ALL DIMENSIONS ARE SUBJECT TO CHANGE WITHOUT NOTICE.



**BALL VALVE 3 PC BOLTED DESIGN
E230B-BV**

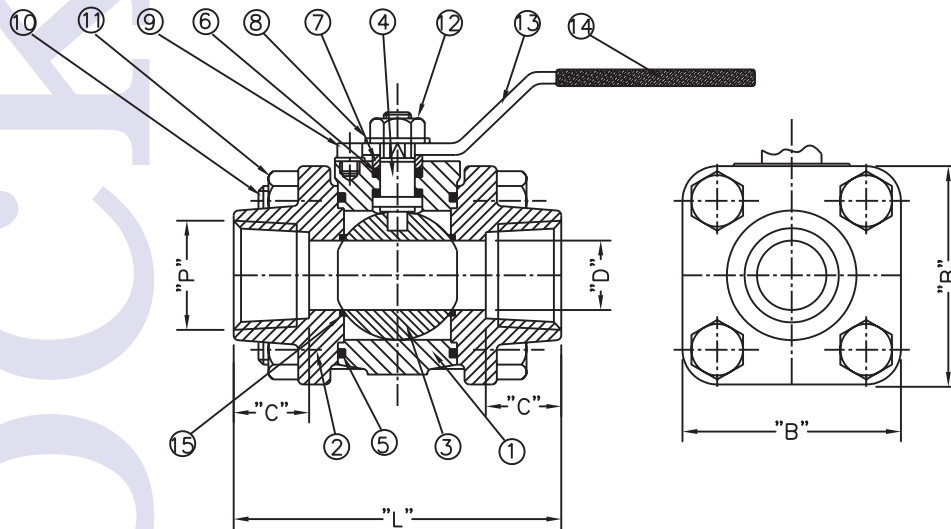

Sr.NO.	DESCRIPTION	MATERIAL	QTY.
1	BODY	SS 316	1
2	ADOPTER	SS 316	2
3	BALL (HARD FACED)	SS 316	1
4	STEM	SS 316	1
5	JOINT SEAL	P.T.F.E.	2
6	GLAND SEAL	TEFLON	2
7	RETAINER	SS 316	1
8	WASHER	SS	1
9	STOP PIN	SS	1
10	STUD	SS	4
11	NUTS	SS	8
12	STEM NUT	SS	1
13	HANDLE	SS	1
14	HANDLE SLEEVE	PVC	1
15	SEAL RING	P.T.F.E.	2

MODEL NO.	"P" NPT(F)	"L" ±2.0	øD ±1.0	C ±1.0	B ±1.0	TEST PRESSURE HYDRO	
						BODY	SEAT
E230B-BV8	1/2" NPT(F)	70.0	12.5	19.0	45.0	3000 PSI	2000 PSI
E230B-BV12	3/4" NPT(F)	80.0	15.0	19.0	50.0	3000 PSI	2000 PSI
E230B-BV16	1.0" NPT(F)	90.0	25.0	22.0	58.0	3000 PSI	2000 PSI
E230B-BV18	1 1/4" NPT(F)	106.0	32.0	22.0	85.0	3000 PSI	2000 PSI
E230B-BV24	2.0" NPT(F)	125.0	50.0	22.0	125.0	3000 PSI	2000 PSI

Note : ALL DIMENSIONS ARE SUBJECT TO CHANGE WITHOUT NOTICE.



**BALL VALVE 3PC PANEL MOUNT DESIGN
E240A - BV**

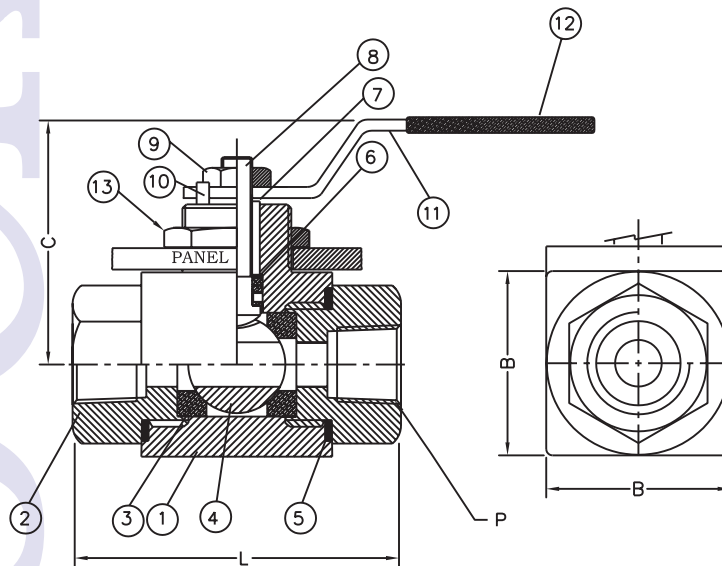

PART No.	PART DESCRIPTION	MATERIAL	QTY
1	BODY	SS316	1
2	ADAPTOR	SS316	2
3	SEAT RING	P.T.F.E.	2
4	BALL	SS316	1
5	GASKET	P.T.F.E.	2
6	GLAND SEAL	P.T.F.E.	2
7	RETAINER NUT	SS316	2
8	STEM	SS316	1
9	LOCK NUT	SS316	1
10	STOPPER PIN	SS316	1
11	HANDLE	SS304	1
12	HANDLE SLEEVE	P.V.C.	1
13	PANEL NUT	SS 316	1

MODEL NO.	P NPT(F)	B	L	C	TEST PRESSURE HYDRO	
E240A-BV4	1/4"	28.0	62.0	52.0	3000 PSI BODY	2000 PSI SEAT
E240A-BV6	3/8"	28.0	62.0	52.0	3000 PSI BODY	2000 PSI SEAT
E240A-BV8	1/2"	35.0	85.0	70.0	3000 PSI BODY	2000 PSI SEAT
E240A-BV12	3/4"	40.0	100.0	70.0	3000 PSI BODY	2000 PSI SEAT
E240A-BV16	1.0"	50.0	110.0	85.0	3000 PSI BODY	2000 PSI SEAT

Note : ALL DIMENSIONS ARE SUBJECT TO CHANGE WITHOUT NOTICE.



**BALL VALVE 3PC. SCREWED DESIGN
E220T - BV**

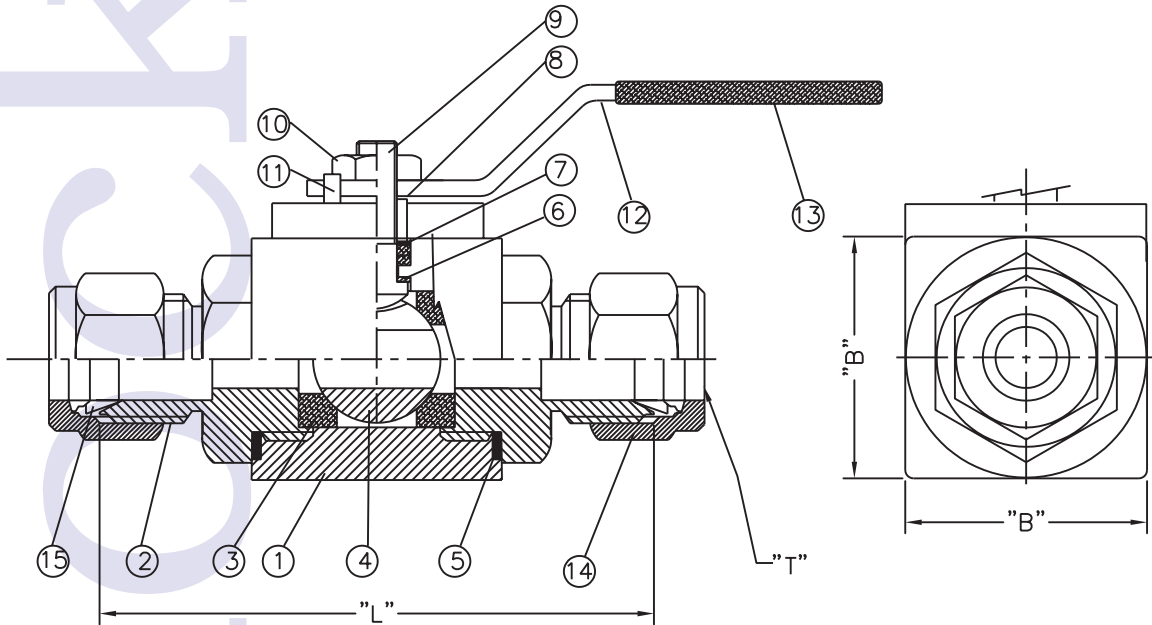

PART No.	PART DESCRIPTION	MATERIAL	QTY
1	BODY	SS316	1
2	ADAPTOR	SS316	2
3	SEAT RING	P.T.F.E.	2
4	BALL	SS316	1
5	GASKET	P.T.F.E.	2
6	SEAL RING	P.T.F.E.	1
7	GLAND SEAL	P.T.F.E.	2
8	RETAINER NUT	SS316	2
9	STEM	SS316	1
10	LOCK NUT	SS316	1
11	STOPPER PIN	SS316	1
12	HANDLE	SS304	1
13	HANDLE SLEEVE	P.V.C.	1
14	NUT	SS316	2
15	FERRULE SET	SS316	2



MODEL NO.	"T" TUBE OD	B	L	TEST PRESSURE HYDRO	
E220T-BV4	1/4"OD	35.0	68.0	3000 PSI BODY	2000 PSI SEAT
E220T-BV6	3/8"OD	35.0	68.0	3000 PSI BODY	2000 PSI SEAT
E220T-BV8	1/2"OD	38.0	76.0	3000 PSI BODY	2000 PSI SEAT
E220T-BV12	3/4"OD	45.0	86.0	3000 PSI BODY	2000 PSI SEAT
E220T-BV16	1.0"OD	50.0	86.0	3000 PSI BODY	2000 PSI SEAT

Note : ALL DIMENSIONS ARE SUBJECT TO CHANGE WITHOUT NOTICE.



**3WAY BALL VALVES
E250W3 - BV**

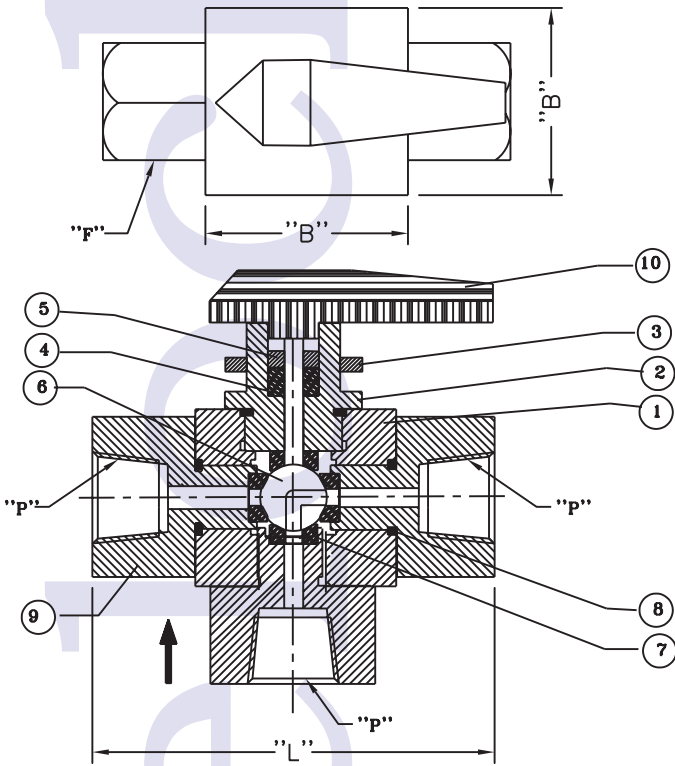

NO.	DESCRIPTION	MATRL.	QTY.
01	BODY	SS316	01
02	GLAND BODY	SS316	01
03	CHECK NUT	SS316	01
04	GLAND PACKING	P.T.F.E.	02
05	GLAND RETAINER	SS316	01
06	BALL	SS 316	01
07	SEAT	P.T.F.E.	03
08	SEAL	SS316	04
09	ADAPTOR 1/4"NPT(F)	SS316	03
10	HANDLE	BACKLITE	01

MODEL NO.	P NPT(F)	B	L	"F"A/F	TEST PRESSURE HYDRO	
E250W3-BV2	1/8"	24.0	80.0	19.0	3000 PSI BODY	2000 PSI SEAT
E250W3-BV4	1/4"	24.0	90.0	19.0	3000 PSI BODY	2000 PSI SEAT
E250W3-BV6	3/8"	24.0	90.0	22.0	3000 PSI BODY	2000 PSI SEAT
E250W3-BV8	1/2"	32.0	100.0	27.0	3000 PSI BODY	2000 PSI SEAT
E250W3-BV12	3/4"	42.0	100.0	36.0	3000 PSI BODY	2000 PSI SEAT

Note : ALL DIMENSIONS ARE SUBJECT TO CHANGE WITHOUT NOTICE.



**3WAY BALL VALVES TUBE OD
E250W3T - BV**

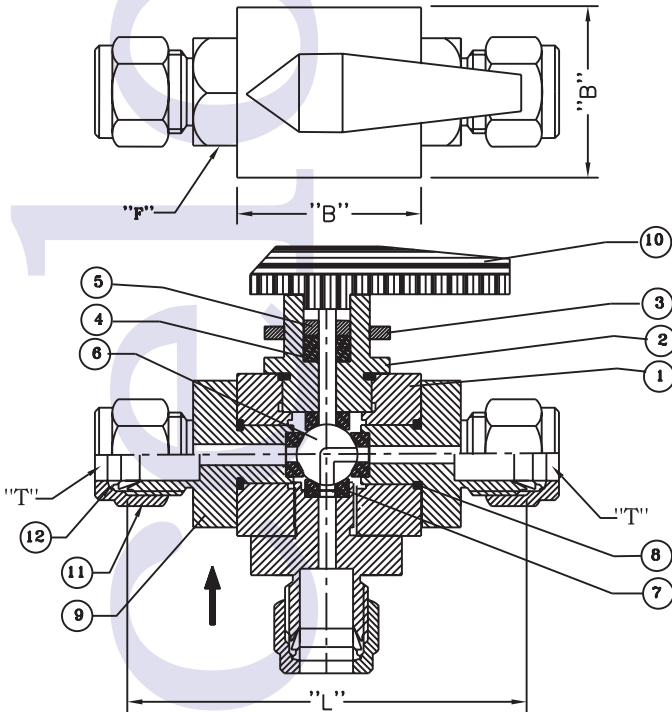

NO.	DESCRIPTION	MATRL.	QTY.
01	BODY	SS316	01
02	GLAND BODY	SS316	01
03	CHECK NUT	SS316	01
04	GLAND PACKING	P.T.F.E.	02
05	GLAND RETAINER	SS316	01
06	BALL	SS 316	01
07	SEAT	P.T.F.E.	03
08	SEAL	SS316	04
09	ADAPTOR 1/4"OD	SS316	03
10	HANDLE	BACKLITE	01
11	NUT	SS 316	03
12	FERULE SET	SS 316	03

MODEL NO.	T TUBE OD	B	L	"F"A/F	TEST PRESSURE HYDRO	
E250W3T-BV2	1/8"	24.0	80.0	19.0	3000 PSI BODY	2000 PSI SEAT
E250W3T-BV4	1/4"	24.0	90.0	19.0	3000 PSI BODY	2000 PSI SEAT
E250W3T-BV6	3/8"	24.0	90.0	22.0	3000 PSI BODY	2000 PSI SEAT
E250W3T-BV8	1/2"	32.0	100.0	27.0	3000 PSI BODY	2000 PSI SEAT
E250W3T-BV12	3/4"	42.0	100.0	36.0	3000 PSI BODY	2000 PSI SEAT

Note : ALL DIMENSIONS ARE SUBJECT TO CHANGE WITHOUT NOTICE.



**4 WAY BALL VALVE
E250W4-BV**

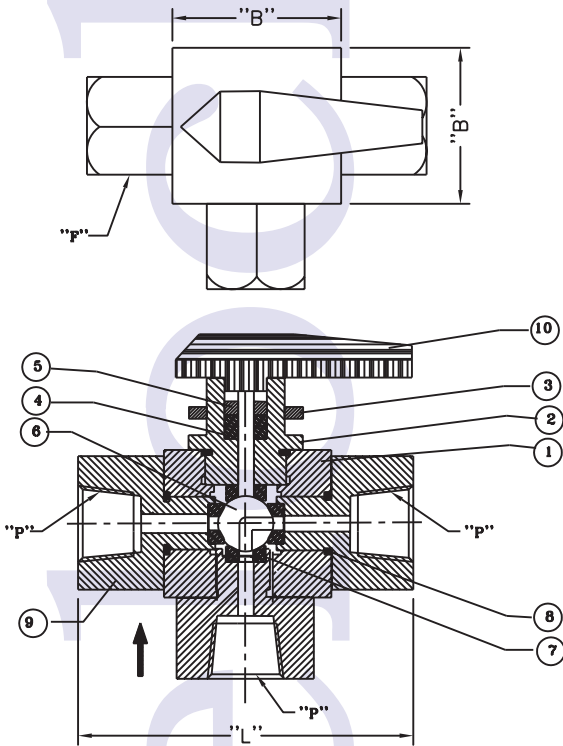

NO.	DESCRIPTION	MATRL.	QTY.
01	BODY	SS316	01
02	GLAND BODY	SS316	01
03	CHECK NUT	SS316	01
04	GLAND PACKING	P.T.F.E.	02
05	GLAND RETAINER	SS316	01
06	BALL	SS 316	01
07	SEAT	P.T.F.E.	04
08	SEAL	SS316	05
09	ADAPTOR 1/4"NPT(F)	SS316	04
10	HANDLE	BACKLITE	01

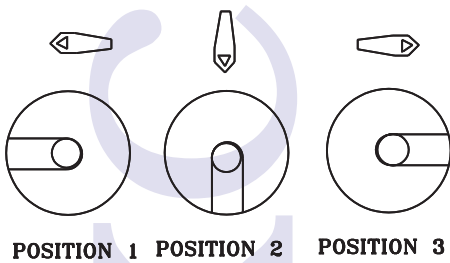

MODEL NO.	P NPT(F)	B	L	"F" A/F	TEST PRESSURE HYDRO	
E250W4-BV2	1/8"	24.0	80.0	19.0	3000 PSI BODY	2000 PSI SEAT
E250W4-BV4	1/4"	24.0	90.0	19.0	3000 PSI BODY	2000 PSI SEAT
E250W4-BV6	3/8"	24.0	90.0	22.0	3000 PSI BODY	2000 PSI SEAT
E250W4-BV8	1/2"	32.0	100.0	27.0	3000 PSI BODY	2000 PSI SEAT
E250W4-BV12	3/4"	42.0	100.0	36.0	3000 PSI BODY	2000 PSI SEAT

Note : ALL DIMENSIONS ARE SUBJECT TO CHANGE WITHOUT NOTICE.



**5 WAY BALL VALVE
E250W5-BV**

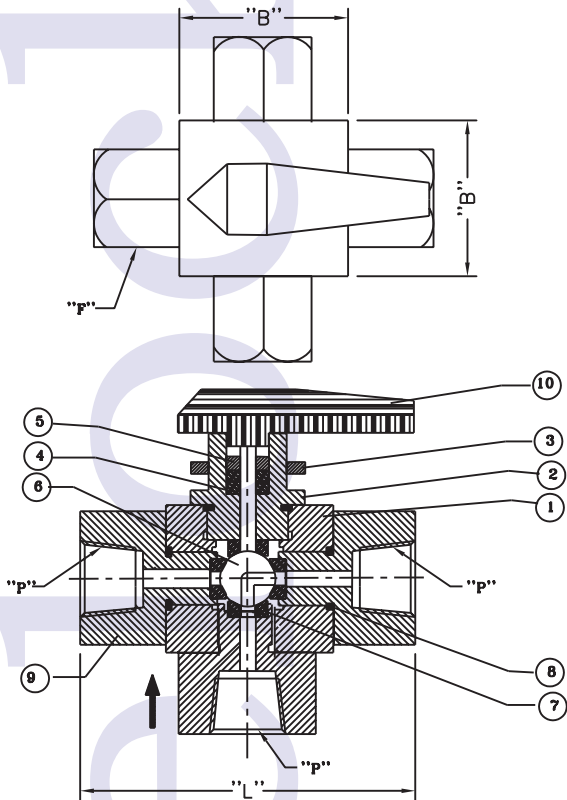

NO.	DESCRIPTION	MATRL.	QTY.
01	BODY	SS316	01
02	GLAND BODY	SS316	01
03	CHECK NUT	SS316	01
04	GLAND PACKING	P.T.F.E.	02
05	GLAND RETAINER	SS316	01
06	BALL	SS 316	01
07	SEAT	P.T.F.E.	05
08	SEAL	SS316	06
09	ADAPTOR 1/4"NPT(F)	SS316	05
10	HANDLE	BACKLITE	01

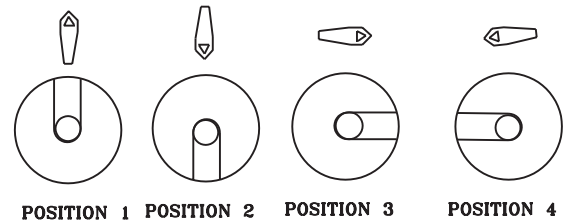

MODEL NO.	P NPT(F)	B	L	"F"A/F	TEST PRESSURE HYDRO	
E250W5-BV2	1/8"	24.0	80.0	19.0	3000 PSI BODY	2000 PSI SEAT
E250W5-BV4	1/4"	24.0	90.0	19.0	3000 PSI BODY	2000 PSI SEAT
E250W5-BV6	3/8"	24.0	90.0	22.0	3000 PSI BODY	2000 PSI SEAT
E250W5-BV8	1/2"	32.0	100.0	27.0	3000 PSI BODY	2000 PSI SEAT
E250W5-BV12	3/4"	42.0	100.0	36.0	3000 PSI BODY	2000 PSI SEAT

Note : ALL DIMENSIONS ARE SUBJECT TO CHANGE WITHOUT NOTICE.



GATE VALVE E210 - GV

Excellock®

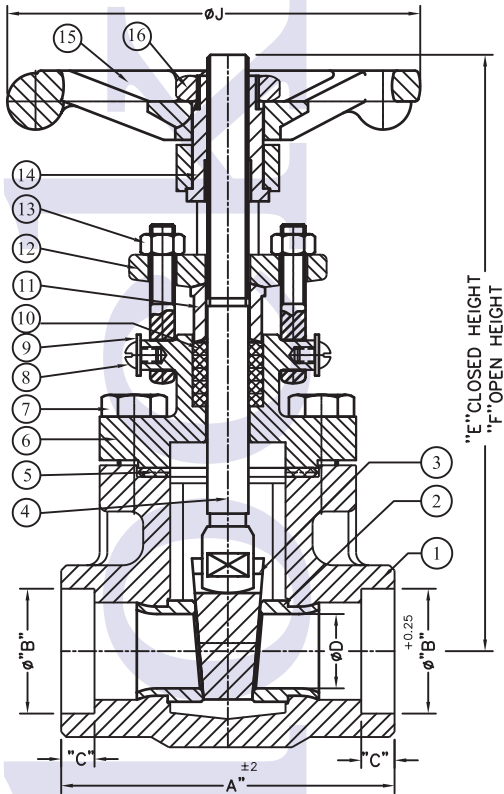

S. NO	DESCRIPTION	QTY.	MATERIAL
1	BODY	1	ASTM-A-182 F304/316
2	SEAT RING	2	AISI - 304/316 + Stellite
3	WEDGE	1	AISI - 304/316 + Stellite
4	SPINDLE	1	AISI - 304/316
5	GASKET	1	SPIRAL WOUND SS 304/316 FILLED WITH ASBESTOS.
6	BONNET	1	ASTM-A-182 F304/316
7	BONNET BOLT	4	ASTM - A - 193 GR . B7
8	SCREW	2	CARBON STEEL
9	WASHER	2	CARBON STEEL
10	PACKING	AS REQ	GRAPHOIL
11	GLAND	1	AISI-304/316
12	GLAND FLANGE	1	AISI-304
13	EYE BOLT & NUT	2	STAINLESS STEEL AISI-304
14	YOKE SLEEVE	1	NI RESIST
15	HAND WHEEL	1	C.I / M.I
16	HAND WHEEL NUT	1	CARBON STEEL

S O C K E T W E L D E N D 800#								TEST PRESSURE HYDRO AT ROOM TEMPERATURE	2000 SEAT 3000 BODY
SIZE	A	B	C	D	E	F	J		
1/2"	87	21.7	9.5	9.5	155	169	85		
3/4"	90	27.1	12.7	12.7	157	174	85		
1.0"	105	33.78	12.7	17.46	172	194	90		
1 1/4"	128	42.57	12.7	23.81	234	262	145		
1 1/2"	128	48.64	12.7	28.58	234	267	145		
2.0"	142	61.11	16	36.5	236	277	145		
S O C K E T W E L D E N D 1500#								TEST PRESSURE HYDRO AT ROOM TEMPERATURE	4075 SEAT 5557 BODY
SIZE	A	B	C	D	E	F	J		
1/2"	90	21.7	9.5	9.5	157	174	89		
3/4"	105	27.1	12.7	12.7	172	194	89		
1.0"	128	33.78	12.7	17.46	234	262	145		
1 1/4"	128	42.57	12.7	23.81	234	267	145		
1 1/2"	142	48.64	12.7	28.58	236	277	145		
S O C K E T W E L D E N D 2500#								TEST PRESSURE HYDRO AT ROOM TEMPERATURE	6787 SEAT 9255 BODY
SIZE	A	B	C	D	E	F	J		
1/2"	128	21.7	9.5	9.5	234	256	145		
3/4"	142	27.1	12.7	12.7	234	264	145		
1.0"	142	33.8	12.7	17.46	236	264	145		

ORDERING INFORMATION : Suffix Model No. by END CONNECTION & CLASS & MOC

TYPICAL MODEL NO : E210 - GV 1/2 "NB 1500 SS316

Note : ALL DIMENSIONS ARE SUBJECT TO CHANGE WITHOUT NOTICE.



**GATE VALVE
E210SR - GV**

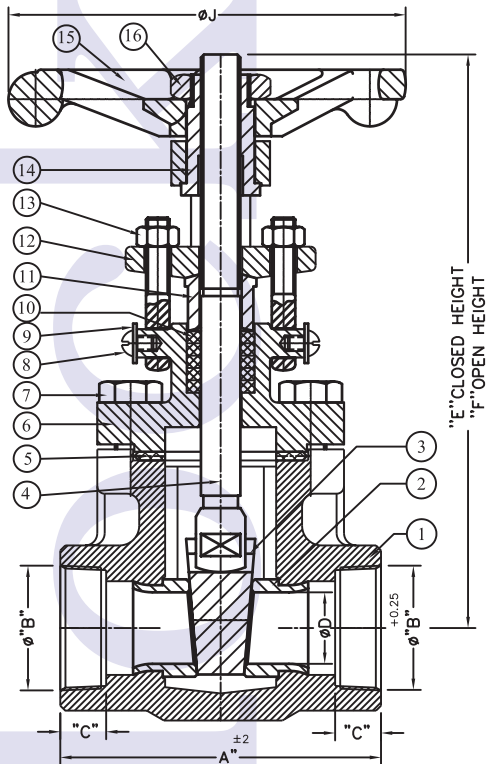

S.NO	DESCRIPTION	QTY.	MATERIAL
1	BODY	1	ASTM-A-182 F304/316
2	SEAT RING	2	AISI - 304/316 + Stellite
3	WEDGE	1	AISI - 304/316 + Stellite
4	SPINDLE	1	AISI - 304/316
5	GASKET	1	SPIRAL WOUND SS 304/316 FILLED WITH ASBESTOS .
6	BONNET	1	ASTM-A-182 F304/316
7	BONNET BOLT	4	ASTM - A - 193 GR . B7
8	SCREW	2	CARBON STEEL
9	WASHER	2	CARBON STEEL
10	PACKING	AS REQ	TEFLON
11	GLAND	1	AISI-304/316
12	GLAND FLANGE	1	AISI-304
13	EYE BOLT & NUT	2	STAINLESS STEEL AISI-304
14	YOKE SLEEVE	1	NI RESIST
15	HAND WHEEL	1	C.I / M.I
16	HAND WHEEL NUT	1	CARBON STEEL

NPT/BSPT THREAD E N D 800#								TEST PRESSURE HYDRO AT ROOM TEMPERATURE	3000 BODY 2000 SEAT
SIZE	A	B	C	D	E	F	J		
1/2"	87	1/2"NPT / 1/2"BSPT	19.0	9.5	155	169	85		
3/4"	90	3/4"NPT / 3/4"BSPT	19.0	12.7	157	174	85		
1.0"	105	1.0"NPT / 3/4"BSPT	24.0	17.46	172	194	90		
1 1/4"	128	1 1/4"NPT / 1 1/4"BSPT	24.0	23.81	234	262	145		
1 1/2"	128	1 1/2"NPT / 1 1/2"BSPT	24.0	28.58	234	267	145		
2.0"	142	2.0"NPT / 2.0"BSPT	24.0	36.5	236	277	145		
NPT/BSPT THREAD E N D 1500#								TEST PRESSURE HYDRO AT ROOM TEMPERATURE	5557 BODY 4075 SEAT
SIZE	A	B	C	D	E	F	J		
1/2"	90	1/2"NPT / 1/2"BSPT	19.0	9.5	157	174	89		
3/4"	105	3/4"NPT / 3/4"BSPT	19.0	12.7	172	194	89		
1.0"	128	1.0"NPT / 3/4"BSPT	24.0	17.46	234	262	145		
1 1/4"	128	1 1/4"NPT / 1 1/4"BSPT	24.0	23.81	234	267	145		
1 1/2"	142	1 1/2"NPT / 1 1/2"BSPT	24.0	28.58	236	277	145		
NPT/BSPT THREAD E N D 2500#								TEST PRESSURE HYDRO AT ROOM TEMPERATURE	9255 BODY 6787 SEAT
SIZE	A	B	C	D	E	F	J		
1/2"	128	1/2"NPT / 1/2"BSPT	19.0	9.5	234	256	145		
3/4"	142	3/4"NPT / 3/4"BSPT	19.0	12.7	234	264	145		
1.0"	142	1.0"NPT / 3/4"BSPT	24.0	17.46	236	264	145		

ORDERING INFORMATION : Suffix Model No. by END CONNECTION & CLASS & MOC

TYPICAL MODEL NO : E210SR - GV 1/2 "FNPT 1500 SS316

Note : ALL DIMENSIONS ARE SUBJECT TO CHANGE WITHOUT NOTICE.



**GATE VALVE
E210FF - GV**

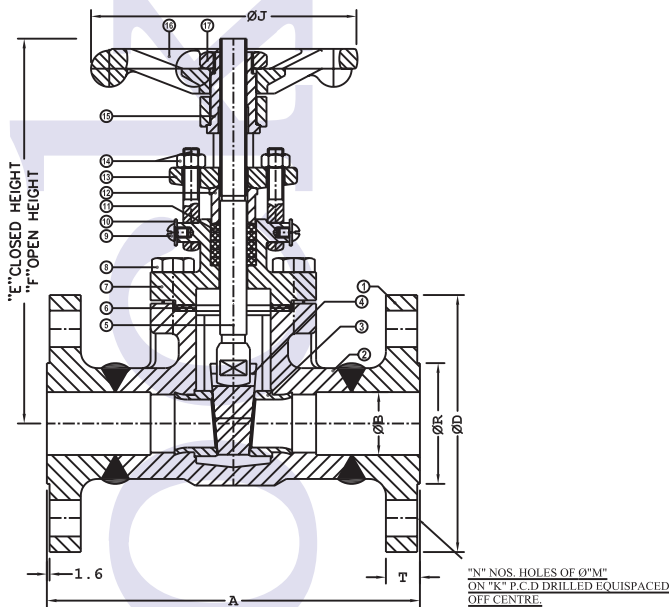

S.NO	DESCRIPTION	QTY.	MATERIAL
1	END FLANGES	2	ASTM - A - 182 F/304 -316
2	BODY	1	ASTM - A - 182 F/304 -316
3	SEAT RING	2	AISI - 304 / 316
4	WEDGE	1	AISI - 304 / 316
5	SPINDLE	1	AISI - 304 / 316
6	GASKET	1	SPIRAL WOUND S304/316 FILLED ASBESTOS.
7	BONNET	1	ASTM - A - 182 F/304 - 316
8	BONNET BOLT	4	ASTM - A - 193 GR . B7
9	SCREW	2	CARBON STEEL
10	WASHER	2	CARBON STEEL
11	PACKING	AS REQ	TEFLON/GRAPHOIL
12	GLAND	1	AISI - 304 / 316
13	GLAND FLANGE	1	ASTM - A - 304
14	EYE BOLT & NUT	2	AISI - 304
15	YOKE SLEEVE	1	NI RESIST
16	HAND WHEEL	1	C.I / M.I
17	HAND WHEEL NUT	1	CARBON STEEL

- MANUFACTURING STANDARD - API - 602 / BS - 5352 .
- TESTING STANDARD - API - 598 / BS - 5146 .
- END FLANGES AS PER - ANSI B - 16.5 .
- FACE TO FACE AS PER - ANSI - B - 16.10 .
- ALL THE VALVES ARE HAVING BACK SEAT ARRANGEMENT.
- STELLITE FACING ON SEAT SURFACE IS DONE IF SPECIFIED IN P.O.

- NOTE:
- RAISED FACED THICKNESS FOR 150# & 300# IS 1.6mm
 - RAISED FACED THICKNESS FOR 600# ONWARDS IS 6.3mm
 - RAISED FACED THICKNESS FOR 150# & 300# IS INCLUDED WITH FLANGE THICKNESS
 - RAISED FACED THICKNESS FOR 600# & ABOVE IS NOT INCLUDED WITH FLANGE THICKNESS

ALL DIMENSIONS ARE IN MM.

CLASS 150 #											
SIZE	B	A	D	R	T	K	M	N	J	E	F
½"	12.7	108.0	89.0	35.0	11.0	60.5	16.0	4	89	155	169
¾"	19	117.5	98.5	43.0	11.0	70.0	16.0	4	89	157	174
1.0"	25.4	127.0	108.0	51.0	11.0	79.0	16.0	4	89	172	194
1¼"	32	140.0	117.5	63.5	12.7	89.0	16.0	4	146	234	262
1½"	38	165.0	127.0	73.0	14.0	98.5	16.0	4	146	234	267
2.0"	50.8	178	152.0	92.0	16.0	120.5	19.0	8	146	236	277
CLASS 300 #											
SIZE	B	A	D	R	T	K	M	N	J	E	F
½"	12.7	140	95.0	35.0	14.2	66.5	16.0	4	89	155	169
¾"	19	152	117.5	43.0	15.7	82.5	19.0	4	89	157	174
1.0"	25.4	165	124.0	51.0	17.5	89.0	19.0	4	89	172	194
1¼"	32	178	133.5	63.5	20.5	98.5	19.0	4	146	234	262
1½"	38	190.5	155.5	73.0	22.3	114.5	22.0	4	146	234	267
2.0"	50.8	216	165.0	92.0	25.4	127.0	19.0	8	146	236	277
CLASS 600 #											
SIZE	B	A	D	R	T	K	M	N	J	E	F
½"	12.7	165.1	95.0	35.0	14.2	66.5	16.0	4	89	155	169
¾"	19	190.5	117.5	43.0	15.7	82.5	19.0	4	89	157	174
1.0"	25.4	215.9	124.0	51.0	17.5	89.0	19.0	4	89	172	194
1¼"	32	229.0	133.5	63.5	20.5	98.5	19.0	4	146	234	262
1½"	38	241.0	155.5	73.0	22.3	114.5	22.0	4	146	234	267
2.0"	50.8	292.0	165.0	92.0	25.4	127.0	19.0	8	146	236	277

ORDERING INFORMATION : Suffix Model No. by END CONNECTION & CLASS & MOC

TYPICAL MODEL NO : E210FF - GV 1/2 "NB 600 SS316

Note : ALL DIMENSIONS ARE SUBJECT TO CHANGE WITHOUT NOTICE.



**CHECK VALVE
E210 - CKV**

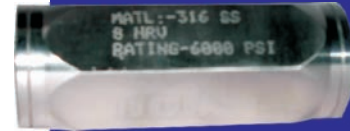
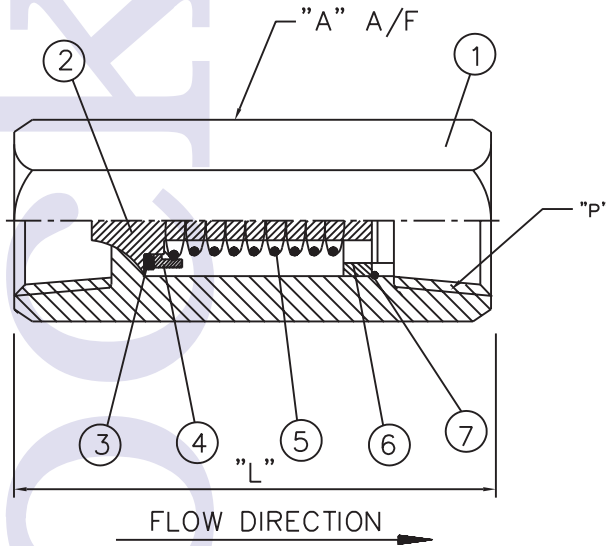

SR.NO.	DESCRIPTION	MATERIAL	QTY.
1	BODY	SS 316	1
2	PISTON	SS 316	1
3	WASHER	NEOPRENE RUBBER	1
4	PISTON RING	SS 316	1
5	SPRING	SS 316	1
6	SPRING SUPPORT	SS 316	1
7	LOCK WASHER	SS 316	1

MODEL NO.	"P"	"A" ± 0.40	"L" ± 0.80	TEST PRESSURE
E210-CKV2	1/8"NPT(F)	16.0	57.0	3000 PSI HYDRO
E210-CKV4	1/4"NPT(F)	19.0	57.0	3000 PSI HYDRO
E210-CKV6	3/8"NPT(F)	22.0	57.0	3000 PSI HYDRO
E210-CKV8	1/2"NPT(F)	27.0	65.0	3000 PSI HYDRO
E210-CKV12	3/4"NPT(F)	36.0	65.0	3000 PSI HYDRO
E210-CKV16	1.0"NPT(F)	45.0	65.0	3000 PSI HYDRO

ORDERING INFORMATION : Suffix Model No. by MOC

TYPICAL MODEL NO : E210 - CKV4 SS316

Note : ALL DIMENSIONS ARE SUBJECT TO CHANGE WITHOUT NOTICE.



**GLOBE VALVE - SWING BOLTED TYPE
E210SW - GB**

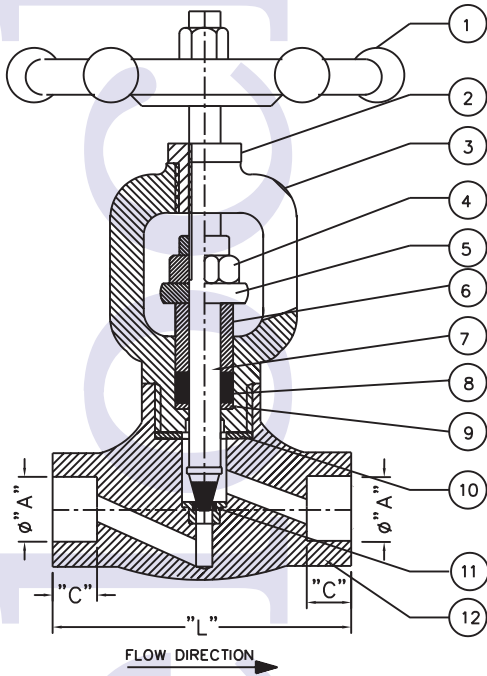

SR. NO.	DESCRIPTION	MATERIAL	QTY. NOS.
01	HANDL WHEEL	CAST IRON	01
02	YOKE NUT	S.S.	01
03	BONNET	ASTM A182 F316	01
04	GLAND BOLT & NUT	S.S.	02
05	GLAND FLANGE	S.S.	01
06	GLAND RETAINER	S.S.	01
07	SPINDLE	SS 316 (TRIM STELLITED)	01
08	GLAND PACKING	GRAPHOIL	03
09	GLAND WASHER	SS 316	01
10	WASHER	SS 316	01
11	SEAT (STELITED)	SS 316	01
12	BODY	ASTM A182 F316	01

SIZE NB(SW)	"A" +0.5	"L" ± 1.0	"C" ± 1.0	CLASS	TEST PRESSURE HYDRO
1/2"	21.7	84.0	10.0	800#	3000 PSI-BODY, 2000 PSI-SEAT
3/4"	27.0		12.7		
1/2"	21.7	84.0	10.0	1500#	5537 PSI-BODY, 4075 PSI-SEAT
3/4"	27.0		12.7		
1/2"	21.7	84.0	10.0	2500#/ 3000#	9255 PSI-BODY, 6787 PSI-SEAT
3/4"	27.0		12.7		

ORDERING INFORMATION : Suffix Model No. by END CONECTION CLASS MOC

TYPICAL MODEL NO : E210SW - GB 1/2"NB 800 SS316

Note : ALL DIMENSIONS ARE SUBJECT TO CHANGE WITHOUT NOTICE.



**GLOBE VALVE - OS & Y TYPE
E220SW - GB**

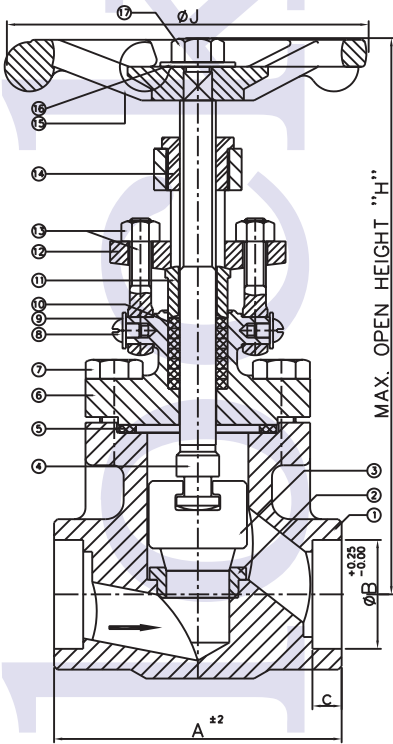

S.no	DESCRIPTION	Qty	MATERIAL
1	BODY	1	ASTMA105/ASTM A182 Gr.F22
2	SEAT RING	1	AISI - 410 STELLITED
3	PLUG	1	AISI - 410 STELLITED
4	SPINDLE	1	ASTM A182 Gr.F6A/AISI 410
5	GASKET	1	SPIRAL WOUND SS/304 FILLED WITH GRAPHOIL
6	BONNET	1	ASTMA105/ASTM A182 GR.F22
7	BONNET BOLT	4	ASTM A - 193 GR B7
8	SCREW	2	C.S.
9	WASHER	2	C.S.
10	GLAND PACKING	4	GRAPHOIL
11	GLAND	1	AISI - 410
12	GLAND FLANGE	1	CARBON STEEL
13	EYE BOLT & NUT	2	SS.AISI - 410
14	YOKE NUT	1	SS 410
15	HAND WHEEL	1	CAST IRON
16	H.WHEEL WASHER	1	C.S.
17	H.WHEEL NUT	1	C.S.

S O C K E T W E L D E N D 800#						
SIZE	A	B	C	E	F	J
½"	87	21.7	9.5	155	169	85
¾"	90	27.1	12.7	157	174	85
1.0"	105	33.78	12.7	172	194	90
1¼"	128	42.57	12.7	234	262	145
1½"	128	48.64	12.7	234	267	145
2.0"	142	61.11	16	236	277	145
S O C K E T W E L D E N D 1500#						
SIZE	A	B	C	E	F	J
½"	90	21.7	9.5	157	174	89
¾"	105	27.1	12.7	172	194	89
1.0"	128	33.78	12.7	234	262	145
1¼"	128	42.57	12.7	234	267	145
1½"	142	48.64	12.7	236	277	145
S O C K E T W E L D E N D 2500#						
SIZE	A	B	C	E	F	J
½"	128	21.7	9.5	234	256	145
¾"	142	27.1	12.7	234	264	145
1.0"	142	33.8	12.7	236	264	145

TEST PRESSURE HYDRO AT ROOM TEMPERATURE
 2000 SEAT
 3000 BODY
 4075 SEAT
 5557 BODY
 6787 SEAT
 9255 BODY

ORDERING INFORMATION : Suffix Model No. by END CONNECTION & CLASS & MOC

TYPICAL MODEL NO : E220SW - GB 1/2"NB 1500 SS316

Note : ALL DIMENSIONS ARE SUBJECT TO CHANGE WITHOUT NOTICE.



SAMPLING CYLINDER E880-SC

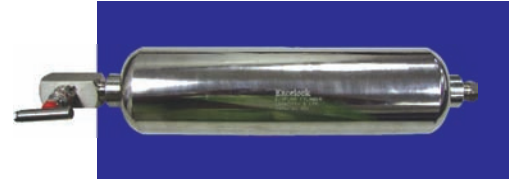
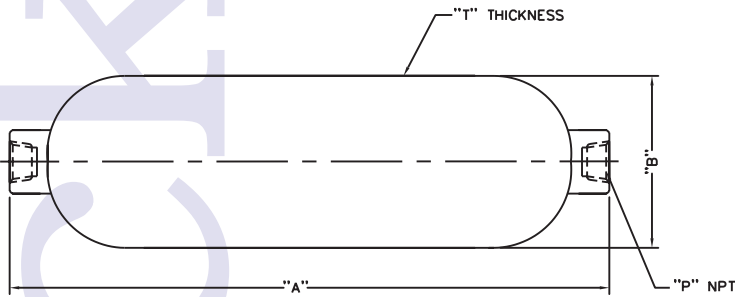

Specifications :

- Manufactured from pipes / investment casting body
- Body material A312 TP304L or A312 TP316L.
- Capacity (Internal Volume) from 150 ml To 3785 ml
- End connection 1/4", 1/2" or 3/4" FNPT.
- Internal surface machined and solvent washed to provide smooth surface
- Maximum working pressure 1800 PSIG.
- With or without DOT rating.

PRESSURE RATING PSIG	CAPACITY (INTERNAL VOL.) cm ³ ± 5%	"P" NPT	DIMENTIONS		
			"A"	"B"	"T"
1800 PSIG	150	1/4"	135	50.8	2.5
	300		225		
	400		290		
	500		350		
	1000	1/4", 1/2", 3/4"	275	88.9	4.6
	2250		435	102	5.2
	3785		680		

ORDERING INFORMATION : Suffix Model No. by CAPACITY & END CONNECTION & MOC

TYPICAL MODEL NO : E880-SC 500 1/4" SS316

Note : ALL DIMENSIONS ARE SUBJECT TO CHANGE WITHOUT NOTICE.



CONDENSATE & SEAL POT
E801, E802 & E803

E801

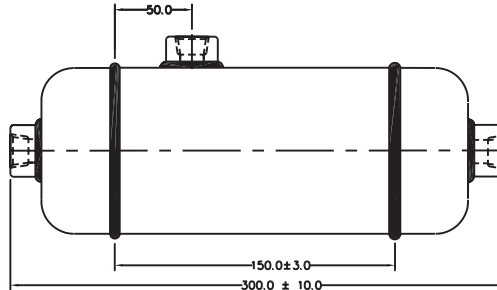

E802

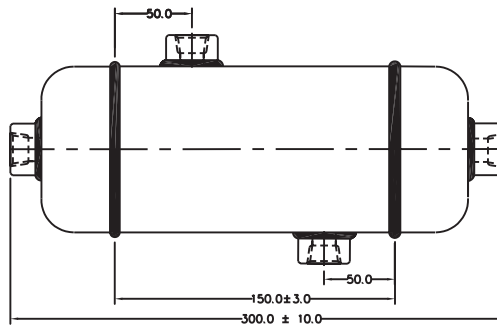

E803

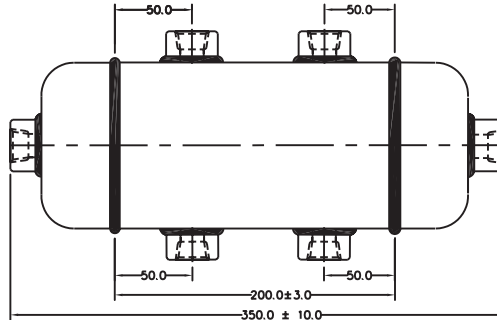

MATERIAL	SCHEDULE 40		SCHEDULE 80		SCHEDULE 160		SCHEDULE XXS	
	PRESSURE TEST		PRESSURE TEST		PRESSURE TEST		PRESSURE TEST	
	Kg./cm ²	PSI	Kg./cm ²	PSI	Kg./cm ²		Kg./cm ²	PSI
A106 Gr.B	80	1150	125	1800	210	3000		
A312 TP316	95	1350	155	2200				
A335 P11			125	1800	210	3000	190	4100

AVAILABLE IN 1/2" THREADED / SOCKET WELD END CONNECTION

ORDERING INFORMATION : Suffix Model No. by **MOC & PIPE SIZE & SOCKET END CONNECTION**

TYPICAL MODEL NO : E801 - SS316 - 3"NB X SCH 80 - SW

Note : ALL DIMENSIONS ARE SUBJECT TO CHANGE WITHOUT NOTICE.



**INSTRUMENT ENCLOSURES
E840 - IE**



Instrument Enclosures / Sun Shades

These hot moulded, FRP / GRP enclosures and sunshades are light weight and fire retardant . They offer a high degree of protection to the instrument against corrosive atmosphere, tampering , accidental damages and too much dust. These are available with lockable lids and windows to allow instrument reading without opening the enclosure . A Specially designed manifold is used for direct instrument mounting, thereby eliminating extra bracketing. This cuts operational cost and potential leak paths.



OTHER ACCESSORIES

Gauge Syphon (GS001)

Syphons allow heat to dissipate, and protect instruments from high temperature. They prevent live system contact with the instrument. These coiled pipes are available in alloy steel or stainless steel with butt weld or threaded ends. Optional IBR approval is offered, depending upon customer requirement



Gauge Syphon (GS 002)

This Gauge Syphon is designed to replace the earlier model known as Pigtail Syphon and this reduces space, weight, overhanging almost 55%. This provides a thermal barrier between hot vapors and the pressure gauge, pressure Switch, Instruments, it is easy to install and requires nil maintenance.



Quick Release Coupling

Designed for pneumatic and hydraulic line application, these fittings can be quickly connected and disconnected without spillage, while the system in operation. Port size varies from 1/8" to 2" and is available with BSP / NPT. Proof pressure up to 400BAR



Pipe Clamps

These clamps eliminate vibration due to their unique construction. They are available in sizes ranging from 1/8" to 6". They make piping neat and sturdy and also ensuring fitting and connections do not get loosened. HDPE / Aluminum / St. Steel body with top and bottom steel plates.

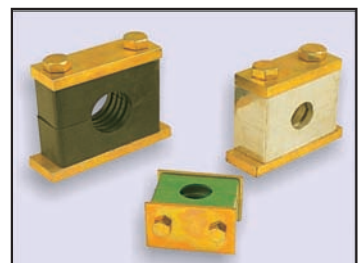



OTHER ACCESSORIES OVAL FLANGE ADAPTOR

Safe and simple connection from process impulse line to instrument or manifold.

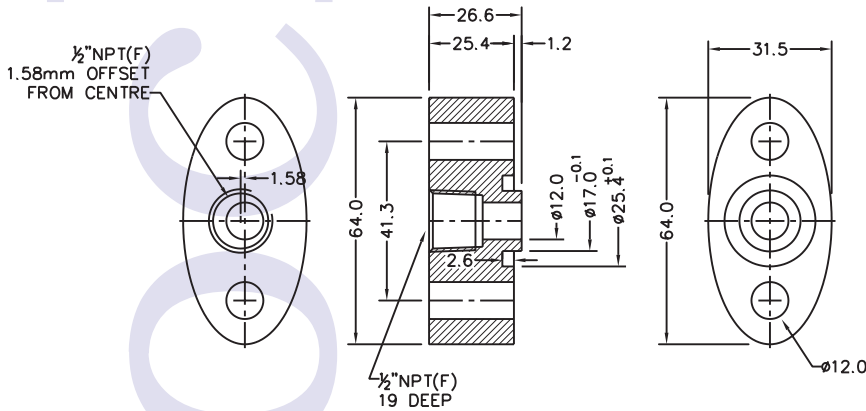

Specification :

Pressure rating 6000psi

Seal ring PTFE / Graphoil (optional)

Body material SS316L / SS316 Other materials on optional.

Tube size : 10mm, 12mm or 1/2" O.D. (Optional)

Butt weld / Socket Weld connections available. (Optional)

NACE compliance available on request.

FLANGE TO COMPRESSION CONNECTOR

Integral body single piece connector. To switch from piping flange standards to instrument compression with minimum cost and better safety. Eliminates the need for additional connections.



Specification :

1/2 " to 2 " NB Flanges to ANSI B16.5

Class : 150 to 2500 lbs

Compression fitting : 1/4 " to 1" O.D. (3mm to 25 mm O.D.)

Flange sealing:- Raised face / RTJ

Variety of Materials available

NACE compliance available on request.



OTHER ACCESSORIES MOUNTING BRACKETS

Mounting Brackets used for mounting manifold to the 2" Stanchion pipe and the Instruments gets mounted to the manifold .

Features : No Need to go to root valve to isolate the instrument.

Isolation valve of the manifold can be used to isolate the process and to remove Instrument for calibration.

Local Calibration can also be done using the vent port of the manifold.

Saving of ordering instrument ahead of the required schedule.

Saves Instrument getting installed when construction work is going on.

As the 'L' bracket has 2" NB radius, there is total surface contact available as against conventional mounting bracket line contacts.

Bracket Part No MB001 (patent pending). "L" Type



Bracket Part No MB002 " C" Type

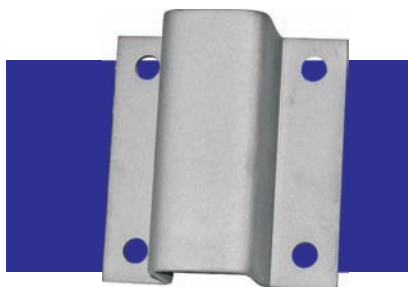



Excelock®

Excelock

CERTIFICATE



Management system as per
DIN EN ISO 9001 : 2000

In accordance with TÜV CERT procedures, it is hereby certified that

HYDRO-PNEUMATIC ACCESSORIES (I) PVT. LTD.
A-791/9, T.T.C. Industrial Estate, MIDC Khairane,
Navi Mumbai 400 705, Maharashtra,
India

applies a quality system in line with the above standard for the following scope:

**Manufacturing and Supply of
Instrumentation Fittings and Valves**

Certificate Registration No. 44 100 074031-E3
Audit Report No. 2.5-3508/2006

Valid until **05.02.2010**

S.K. Kulkarni

TÜV CERT Certification Body
at TÜV NORD CERT GmbH

Mumbai, **06.02.2007**

This certification was conducted in accordance with the TÜV CERT auditing and certification procedures and is subject to regular surveillance audits.

TUV India Pvt. Ltd., 801, Raheja Plaza - 1, L.B.S. Marg, Ghatkopar (W), Mumbai - 400 086, India www.tuvindia.co.in



TGA-ZM-30-96-00



Hydro-Pneumatic Accessories (I) Pvt. Ltd.

INDIA

Excel Hydro-Pneumatics Pvt. Ltd.

149, Raja Industrial Estate
P. K. Road, Mulund - West,
Mumbai - 400080, India.
Phone: + 91-22-2568 3291, 2560 6089
Fax: +91-22-2564 5538
email: excel@bom2.vsnl.net.in

Hydro-Pneumatic Accessories (I) Pvt. Ltd. 100% EOU

Plot No.: A-791/9, T.T.C. Industrial Estate,
M.I.D.C., Khairane, Navi Mumbai - 400 705
Phone: +91-22-2778 0216, 2778 0217
Fax : +91-22-2778 0215
email: hpaipl@vsnl.net

SINGAPORE

Excel Hydro-Pneumatics (S) Pte. Ltd.

04-04A, ECON Building Street 64,
Ang Mo Kio Industrial Park-3,
Singapore - 535127
Phone: + 65-6454 5929
Fax : +65-6452 4314
email: excelsingapore@pacific.net.sg

Cat6-2007

OUR PRODUCT RANGE

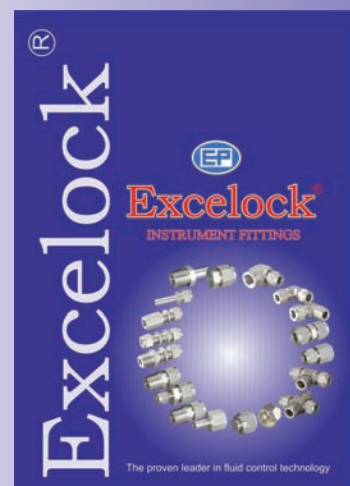
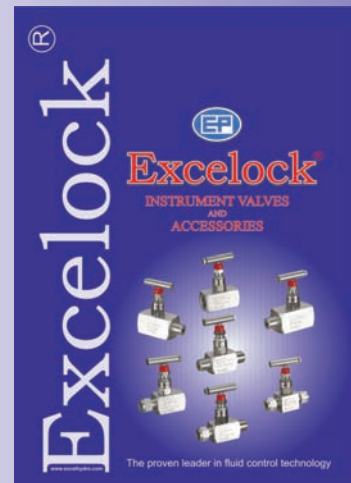
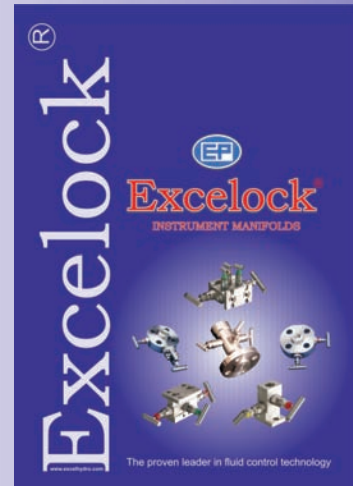

www.excelhydro.com